

SATATYA CIBR20FL36CW-S

2MP IR Bullet Camera with 3.6mm Lens



SATATYA CIBR20FL36CW-S
2MP IR Bullet Camera with 3.6mm Lens

Matrix project series IP Cameras are built using superior components such as Sony STARVIS sensor and higher MTF lens to offer unmatched image quality especially during the low light conditions. Powered by True WDR algorithm, these cameras offer consistent image quality even in highly varying lighting conditions. Built in intelligent analytics including Intrusion Detection, Trip Wire, etc. ensure real-time security. Moreover, H.265 compression and Automatic Motion based Frame Rate Reduction save bandwidth and storage up to 50%.

USP



SONY STARVIS
SENSOR



H.265



IVA



HIGHER FIELD
OF VIEW



SMART
STREAMING



ADAPTIVE
STREAMING



TRUE WDR



NAS

CERTIFICATION



Customer Care: +91 265 2630555

E-mail: Customer.Care@MatrixComSec.com

www.MatrixVideoSurveillance.com

Made in India

SATATYA CIBR20FL36CW-S

2MP IR Bullet Camera with 3.6mm Lens



TECHNICAL SPECIFICATIONS

CAMERA

Sensor Type and Size	1/2.8" SONY CMOS (EXMOR Technology STARVIS Series)
Minimum Illumination	0.08Lux @ F2.0 @ 1/25s, No Sens-up allowed for (Color/Monochrome) and 0Lux with IR LED on for (B/W)
Lens Type	Fixed Iris
Focal Length	3.6mm
FOV	HFOV (degrees) 90°, DFOV (degrees) 110°, VFOV (degrees) 47°
Shutter Speed	1/12500s to 1/25s
SNR	48dB @ 5lux
Lens Mount	M12 x 0.5
Minimum Object Distance	0.3m
Processor, RAM and Flash	HI-3516A , 4GB and 1GB
Aperture	F1.2
IR LED Type	4 - Array LEDs
IR Range	Up to 30m
IR Type	Auto / Manual
IR Power Consumption	8W @ on and 3.5 @ off
Privacy Zone	3 Zones

NETWORK

Network Protocols	TCP/IP, HTTP, DHCP, DNS, DDNS, RTP, RTSP, PPPOE, SMTP, NTP, SNMP, HTTPS, FTP, ONVIF S
-------------------	---

IMAGE AND VIDEO

Video Compression	H.265/H.264/MJPEG
Resolutions	2MP(1920x1080)/720p/D1(704x480)/2CIF(704x288)/CIF(352x240)/QCIF(176x120)
Stream Profiles	Four streams are supported 2MP up to 30 fps(H.265/H.264), D1 up to 5fps(MJPEG), D1 up to 30 fps(H.265/H.264), 720p up to 30 fps(H.265/H.264/MJPEG)
Max. Number of Simultaneous Streams	4
Bitrate	128Kbps - 4Mbps
Frame Rate	1 - 30fps
Image Enhancements	Saturation, Contrast, Brightness, Hue, Sharpness, Rotate, White Balance (Auto/Fluorescent/Incandescent/Sunny)
WDR	True WDR (120dB)
Image Features	ROI, E-PTZ, BLC, Digital Zoom, Image Snapshots, Adaptive Streaming, Smart Streaming (Max. 3 Windows), Unicast/Multicast
DNR	3DNR and 2DNR(Auto/Manual)
Recording Type	Scheduled Edge Recording, Network Recording, Alarm Recording

SATATYA CIBR20FL36CW-S

2MP IR Bullet Camera with 3.6mm Lens



EVENTS AND ACTIONS

Events	Motion Detection, View Tamper, Line Intrusion, Directional Motion, Trip Wire(3 Lines), Zone Intrusion(3 zones), IP-Conflict, Network-Disconnect, Storage Alert
Actions	Email with Snapshot/TCP/SMS Notifications, Alarm Recording, Image/Clip Upload

GENERAL SPECIFICATION

Communication Interface	10Base-T/100BaseTX Ethernet (RJ-45)
SD Card	Up to 128GB (Micro SD)
Power Supply	12V/2A, Poe (IEEE 802.3af)
Power Consumption	7 Watt
Operating and Storage Temperature	0 to 50 Degree / (-)20 to 60 Degree
Operating Humidity	Less than 90% RH
Certifications	BIS,CE, IP66, FCC Part-15 Class-B
System Requirements	Windows7 and above, Browser: IE-8 and above, Plugins: IE-ActiveX, Google Chrome and Mozilla-VLC
Dimension	320 X 84.5 X 92.5mm (L X H X W)
Weight and Color	920gm & White (Beige)
Material Type	Aluminum

SATATYA CIBR20FL36CW-S

2MP IR Bullet Camera with 3.6mm Lens



DIMENSIONS (in mm)

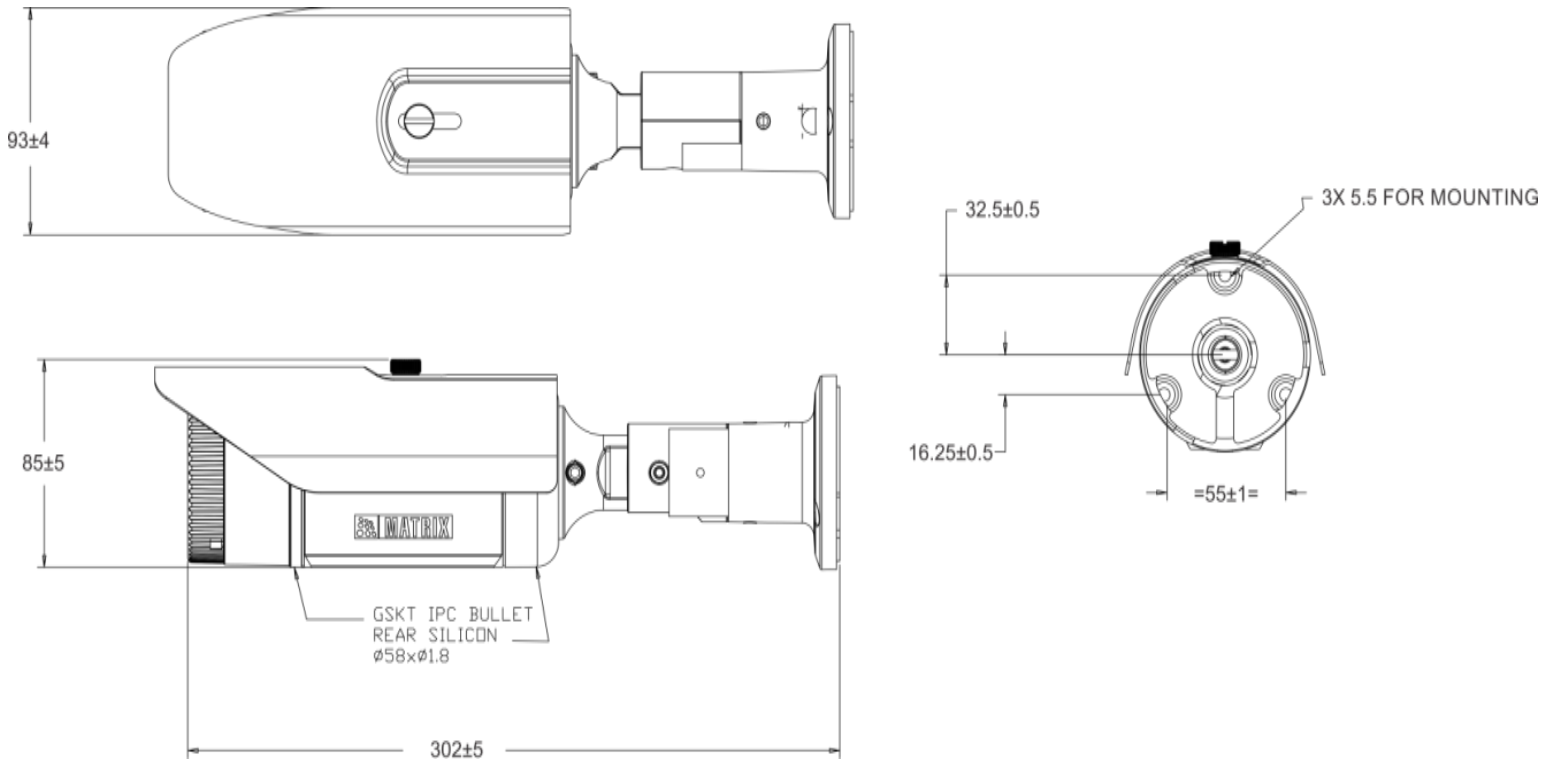

ABOUT MATRIX

Established in 1991, Matrix is a leader in security and telecom solutions for modern businesses and enterprises. Matrix, an innovative, technology driven and customer focused organization, is committed to keep pace with the revolutions in security and telecom industries. With more than 40% of its human resources dedicated to the development of new products, Matrix has launched cutting-edge products such as Unified Communications, IP-PBX, Universal Gateways, Convergence, VOIP Gateways, GSM Gateways, IP Video Surveillance, Access Control and Time-Attendance. These solutions are feature-rich, reliable and conform to the international standards. Having global footprints in Europe, North America, South America, Africa and Asia through an extensive network of more than 1000 system integrators, Matrix ensures that the products serve the needs of its customers faster and longer. Matrix has gained trust and admiration of customers representing the entire spectrum of industries. Matrix has won many national and international awards for its innovative products.

* Specifications are subject to change without prior notice.